

Minimum font size : 6 pt. (2,1 mm)

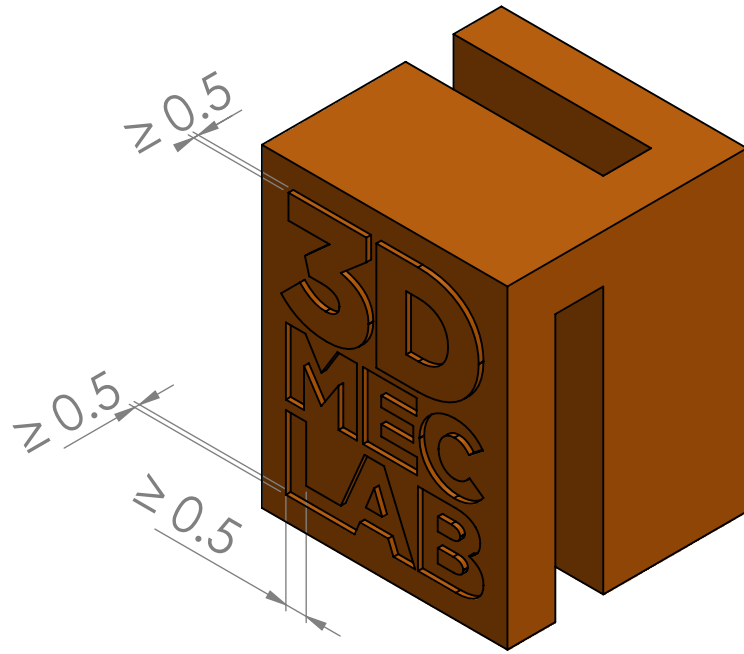

If you want to remove the internal powder make some communicating holes

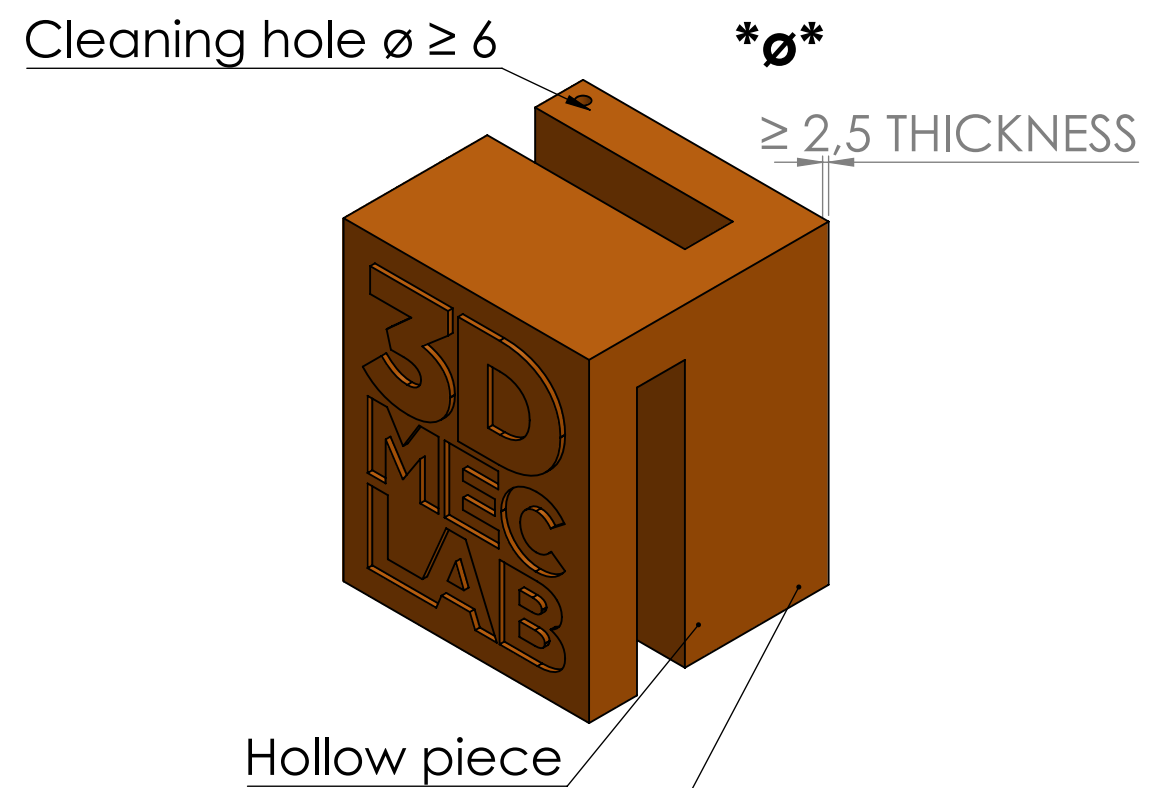

Hollow piece  
Cleaning hole ø ≥ 6

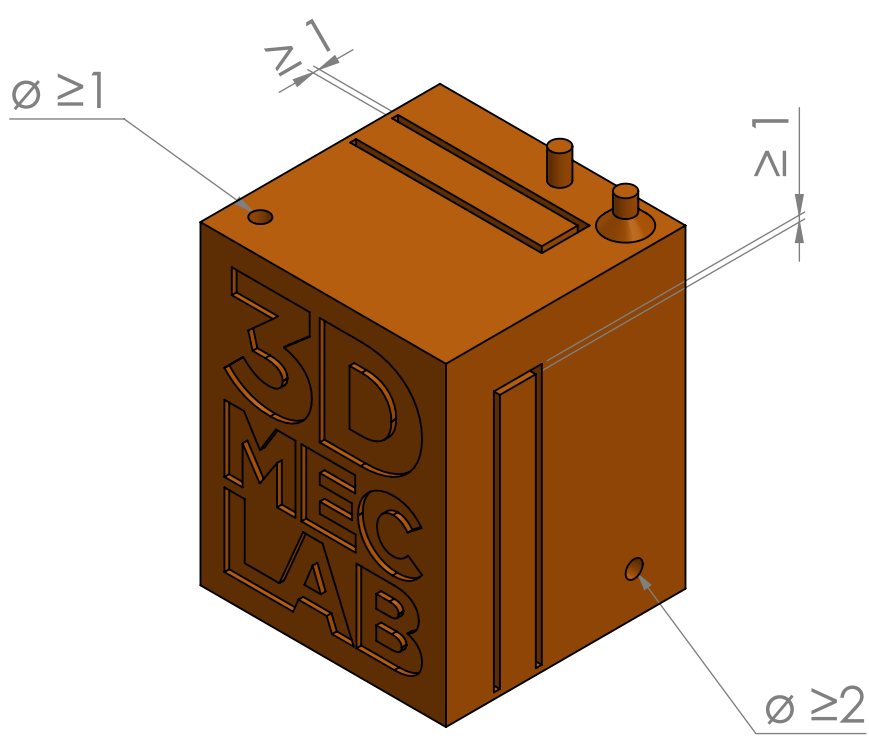

Blind hole depth= 3xø

Over 3xø deep cleaning is not guaranteed

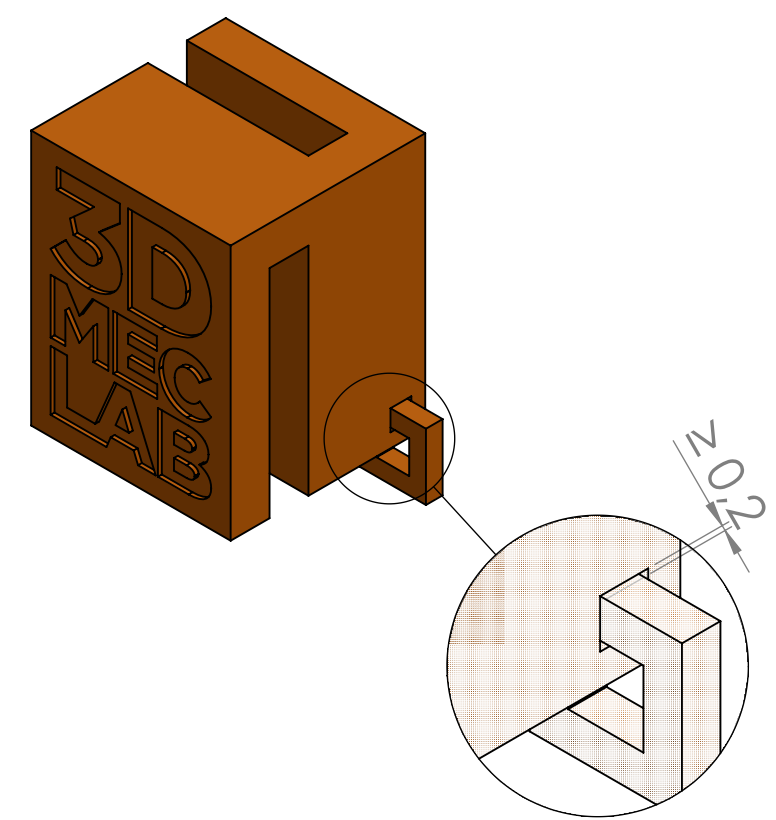
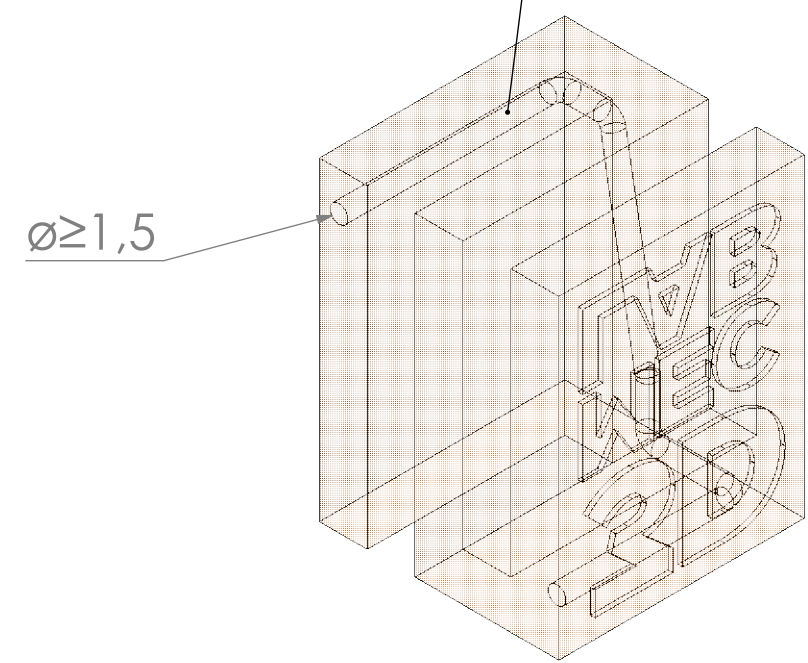

### 3DMECLAB Design Guidelines SLS

- SLS dimensional tolerance: ± 0.3mm, ± 0.3% >100mm
- Walls with a thickness of more than 8 mm will be emptied leaving a minimum thickness of 2-3 mm, to avoid deformation. Inside it remains the unsintered powder
- We advise not to have thin and flat parts in additional to an A5 size